

Absorbant Glass Mat (AGM) technology for superior performance. Valve regulated, spill proof construction allows safe operation in any position. Approved for transport by air, D.O.T., I.A.T.A., F.A.A. and C.A.B. certified. U.L. recognized under file number MH 20567.

Maintenance-Free

Specification

Nominal Voltage	12 volts		
Nominal Capacity	77° F (25° C)		
20-hr. (0.04A)	0.80 Ah		
10-hr. (0.07A)	0.74 Ah		
5-hr. (0.14A)	0.68 Ah		
1-hr. (0.48A)	0.48 Ah		
Approximate Weight	0.75 lbs (0.3 kgs)		
Internal Resistance (approx.)	200mΩ		
Shelf Life (% of normal capacity at 68°F (20°C))			
3 Months	6 Months	12 Months	
91%	83%	64%	
Temperature Dependency of Capacity	(20 hour rate)		
104° F (40°C)	77° F (25°C)	32° F (0°C)	5° F (-15°C)
102%	100%	85%	65%
AGM Operational Temperature			
Charge	32°F to 104°F (0°C to 40°C)		
Discharge	5°F to 113°F (-15°C to 45°C)		
AGM Storage Temperature	5°F to 104°F (-15°C to 40°C)		



Due to continuous improvements to our products, product may vary slightly from depiction.

Charge Method (Constant Voltage)	
Cycle Use (Repeating Use)	
Initial Current	0.24A or smaller
Control Voltage	14.6 - 14.8
Float Use	
Control Voltage	13.6 - 13.8

Physical Dimensions: in (mm)

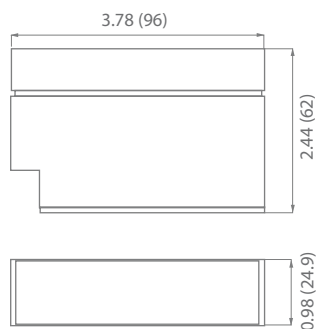

L: 3.78in (96.0 mm)
W: 0.98in (24.9 mm)
H: 2.44in (62.0 mm)
TH: 2.44in (62.0 mm)
 Tolerances are +/- 0.04 in. (+/- 1mm) and +/- 0.08 in. (+/- 2mm) for height dimensions. All data subject to change without notice.

Terminals

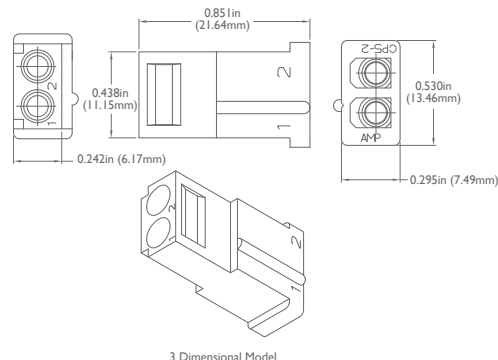

3 Dimensional Model

Discharge Time vs. Discharge Current

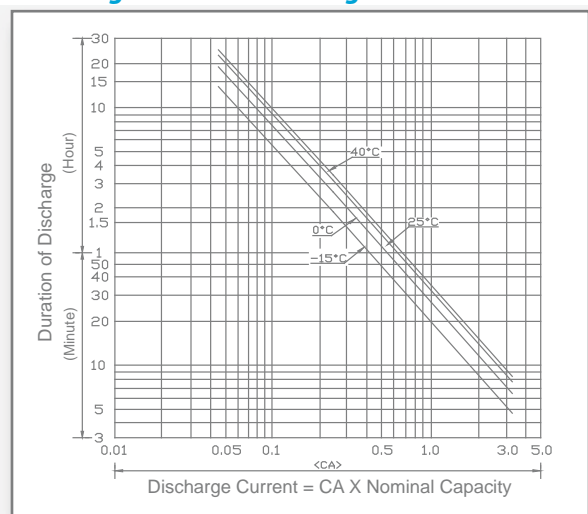

Discharge Characteristics

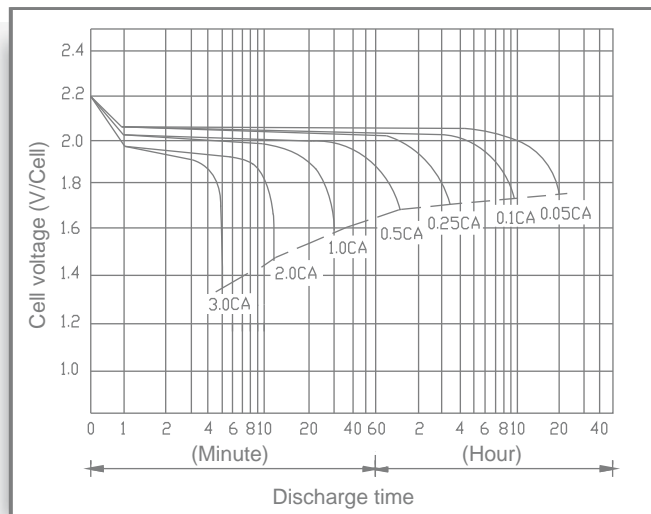

Shelf Life & Storage

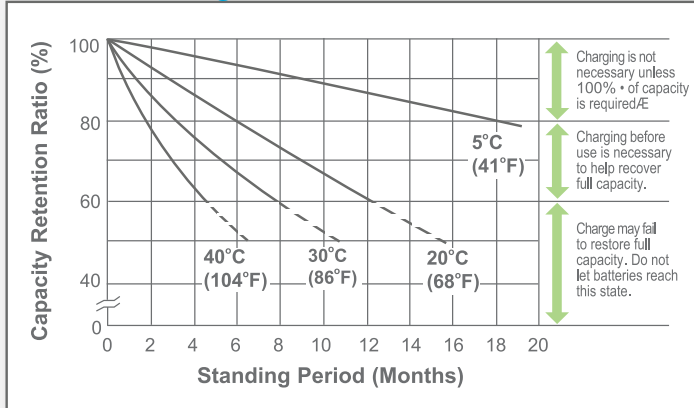

Cycle Life vs Depth of Discharge

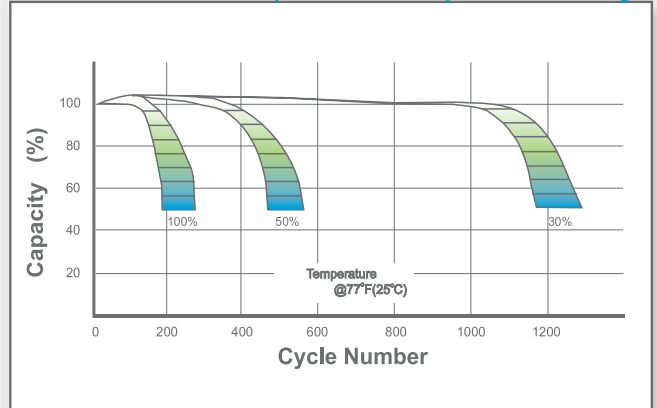

Open Circuit Voltage vs Residual Capacity

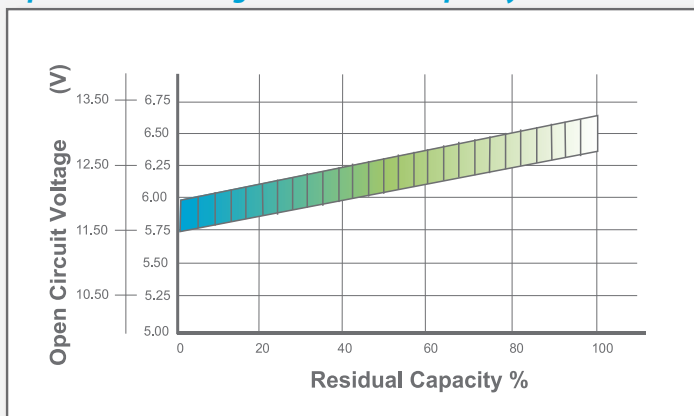

Effect of Temperature on Capacity

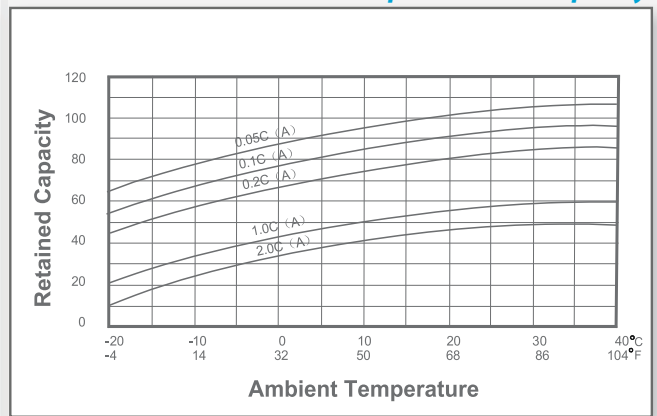

Charge Current & Final Discharge Voltage

Application	Charge Voltage(V/Cell)			Max.Charge Current	Final Discharge Voltage V/Cell	1.75	1.70	1.60	1.30
	Temperature	Set Point	Allowable Range						
Cycle Use	25°C(77°F)	2.45	2.43~2.47	0.30C	Discharge Current(A)	0.2C>(A)	0.2C<(A)<0.5C	0.5C<(A)<1.0C	(A)>1.0C
Standby	25°C(77°F)	2.28	2.27~2.30						